

National RADIO-TV NEWS



IN THIS ISSUE

Auto Radio Parts Replacement
High-Fidelity Audio Power Amplifiers
NRI Alumni Association News

June-July
1956

VOL. 17
No. 3



A Smooth Sea Never Made A Skillful Mariner

Sometimes when the going is pretty rough and you are discouraged and just about ready to quit, it might buck you up a little to recall that on October 11, 1492, a despairing Columbus recorded in his log that his ships "Encountered a heavier sea than they had met with before on the whole voyage."

The next day he discovered America.

When you are down and feel like taking the ten count, come up swinging and fight one more round. One more blow could win the battle.

You are never whipped until you, yourself quit.

There will always be some obstacles to overcome. Everything worth-while in life has a price. The price of success is overcoming hardships, discouragement, solving problems. The test is whether you have the determination to whip these circumstances, or whether you are going to let them whip you.

Nothing seems easy, not even walking, that was not difficult at first. They who are the most persistent, and work in the truest spirit, will usually be the most successful.

If I can say anything to our students that will help them overcome the natural tendency to take the easiest road, to help them show strength when strength is needed, I feel I am contributing as much to their success as I am with the material in their lessons and kits. The best Radio and Television course in the world can do nothing for a man unless he will study, study, study and will beat back all negative influences that hinder him from reaching his goal.

J. E. SMITH, *Founder*

NATIONAL RADIO-TV NEWS

Louis L. Menne, *Editor*
H. L. Emerson, *Associate Editor*
J. B. Straughn, *Technical Editor*

Published every other month by the National Radio Institute, 16th and U Sts., N. W., Washington 9, D. C. Subscription, \$1.00 a year. Printed in U. S. A. Second-class mail privileges authorized at Washington, D. C.

Auto Radio Parts Replacement

By J. B. STRAUGHN

Chief, NRI Consultation Service



J. B. Straughn

THE technician making parts replacements in an auto radio faces a different problem from that encountered in home radios. He must realize that this part, and indeed, the whole set, is going to get much rougher treatment than the average home radio. Therefore, he must take especial pains to see that all parts are mounted in a way that will make them mechanically sturdy, and avoid troubles due to broken leads.

By-pass condensers, for instance, should either be fastened to the chassis with small clips, or slipped under adjacent wiring to hold them firmly in place. They should never be installed so that they are supported by their wire leads. A piece of spaghetti or insulating tubing should be slipped over all exposed wiring to prevent short circuits when parts are jolted or moved. If no other means is handy, large by-pass or filter condensers may be held in place by tying

them to the chassis with a loop of insulated wire run through holes in the chassis.

When replacing filter condensers of the can type, held in place by three or four small metal ears protruding through holes or slots in the chassis, be sure that these ears are well tightened, and that at least *two* of them are soldered down. Failure to do this will result in the condenser working loose under vibration. These ears make the negative or ground connection, and a bad joint here means an intermittent filter condenser. This trouble is quite common, even in brand new sets, through failure to make a good ground at this point.

If the tubular type of filters must be used for replacement, strap them down tightly; never leave them supported by their leads. Always leave a little slack in wire leads. The change in

temperatures encountered inside the auto radio case can cause contraction and expansion strong enough to pull the leads out of by-pass condensers if they are too tightly stretched when installed.

When replacing output transformers, power transformers, chokes, or other heavy parts, be sure that they are well bolted down to the chassis, even if it means drilling one or two new holes. Always use lockwashers under all bolts or screws to prevent loosening. A small dab of paint, cement, or better still, nail polish, applied to the threads of a screw just before tightening, will hold it firmly.

Volume Controls

Volume controls used in auto radios are practically all of the audio-grid type. The signal is taken from the diode second detector and applied to the top of the control. The slider is connected to the first audio grid, sometimes through a coupling condenser, sometimes directly. Values range from 250,000 to 500,000 ohms, just as in home radios. Although some of the early sets used different circuits, such as rf cathode bias controls, these have practically vanished.

Early sets using remote control shafts to operate volume and tuning controls usually provided the control itself with a "slip-joint," to prevent breakage of the control by turning the shaft too far. The single-unit sets today use controls which are practically identical with those used in home radios. The main difference lies in the special physical shapes of the controls themselves, to accommodate the special needs of auto radios.

The control itself is very often one of the three points of support for the whole set. The nuts holding the control to the front panel also hold the front of the set in place.

Many different types of shafts are used on auto radio controls. These include the $\frac{1}{4}$ -inch "quarter-flat," the $\frac{1}{4}$ -inch "half-flat," the $\frac{1}{8}$ -inch "split" shaft, and the $\frac{1}{4}$ -inch round.

Tone control circuits are also similar to those used in home sets. The most common is the "grid-losser" circuit, with a condenser and variable resistor connected in series from the first audio grid to chassis. When rotated, the resistor alters the high-frequency response by by-passing the highs to ground through the condenser.

For reasons of space-saving, dual controls are used in many sets: volume and tone controls using coaxial shafts, with the on-off switch often on the back of the whole thing. If the switch fails, the whole unit must be replaced, unless a duplicate switch happens to be available. If so, the defective switch may be pried off, and the



FIG. 1. Typical construction of remote control shaft. Note three layers, A, B, and C, which are made up of spring-steel wire, wound in opposite directions for stiffness and to eliminate backlash.

new switch installed, held in place by soldering the case to the body of the original control. Of course, this will work only if the switch is an *exact* duplicate of the original, as the "trip-dog" on the volume control will not operate an incorrectly-matched switch.

In most cases, replacement controls for this type of unit must be obtained from the maker of the radio. Due to the use of special sizes, replacement controls must be exact duplicates of the originals if they are to work satisfactorily. Many of the larger control manufacturers offer "exact-duplicate" replacement controls for the more popular sets, and, indeed, may make the ones used in the original sets themselves. These, of course, will work very well.

If the controls are noisy, they may be cleaned, using one of the special solvents made for this purpose. These are put up in bottles with a brush, and in the pressurized "spray-cans," which are very handy in a crowded chassis. This solvent removes the dirt and corrosion, and also leaves a slight film of lubricant on the surfaces of the control. It is a very good idea to give the volume control and switch a squirt each time the set is serviced; this will help to prolong the life of the switch, especially.

Many auto radios use a dual switch, one set of contacts switching the vibrator and tube filaments, the other switching only the pilot or dial light, which has its own input lead. This light-lead is usually connected to the car's light switch at the terminal that supplies current for the instrument panel lights. When replacing these switches, a single-pole switch may be used by simply tying the dial-light lead to the vibrator lead and using only one input lead.

If an exact duplicate replacement switch assembly is not available, or the owner objects to the price, an "outboard" switch may be used instead. Tie the wires from the switch all together inside the set, soldering well, and install a switch, of the type used for fog lights, under the edge of the dash. Connect it into the hot lead from the radio to the car ignition switch.

Remote Control Heads

The remote control head as used on most of the older sets, especially the "universal" type, con-

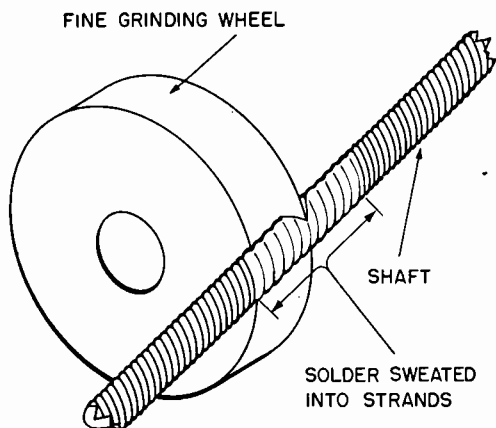

FIG. 2. Cutting flexible shafts, using grinding wheel. After soldering to hold strands, grind notches in alternate sides of shaft until it breaks. Do not allow grinder to heat shaft until solder melts. Outer housings may be cut in the same way.

sists simply of a metal box, which holds the dial scale and pointer, fittings for the tuning and volume control shafts, and a dial light. These are made in such shapes as to fit into the holes provided in the instrument panel for the custom-built radio set. One type is made for "underdash" installation, being small and flat, and may be used in any kind of car.

These heads are connected to the set by means of flexible cables, similar in appearance and operation to speedometer cables. The ends of the inner shaft, which do the actual tuning, are provided with special fittings, known as splines, which engage matching fittings in the control head and inside the set.

If repairs or alterations are necessary to these shafts, a few special precautions are needed. The inner shafts are made of spring wire, with at least three layers being wound in different directions to provide stiffness and eliminate backlash. This construction is shown in Fig. 1. These are kept under tension at all times, and this tension must be maintained. If this shaft must be cut, it is necessary to keep this tension on it at all times.

Mark the location of the cut on the shaft, clean it, then sweat solder into the strands until a space of at least an inch is covered. Cut in the center of this, using a very fine-toothed hacksaw, or better still, a fine-grit grinding wheel. Using the corner of the grinding wheel, as shown in Fig. 2, grind a small notch on each side of the shaft, then bend it until it breaks. Touch up the end smoothly with the wheel. Don't allow the shaft to get too hot, as the solder might melt,

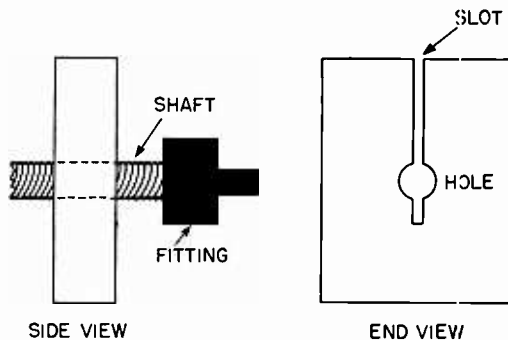

FIG. 3. Home-made "jig" for holding flexible shafts, for removing or replacing fittings, cutting, etc. It is simply a block of metal, aluminum, brass, or any available metal, with a $\frac{1}{8}$ inch hole drilled through it, and a slot cut with a hacksaw down through the hole. In use, it is "pinched" in a vise, with the shaft placed in the hole. The tension allowed by the slot causes the sides of the hole to hold the shaft firmly, preventing their unwinding.

"Swedged" (pressed-on) fittings may be removed by simply unscrewing them with a pair of pliers, using the strands of the shaft as if they were threads on a screw: the replacement fitting must be soldered well in place.

releasing the tension of the wraps and ruining the shaft. The outer housing may be cut in the same way.

To remove and replace the fittings on the ends of the inner shaft, you will need to make a small holding jig. This is merely a block of metal, at least $\frac{1}{2}$ inch thick, and about one inch square. Drill a hole through the flat side the same size as the shaft, about $\frac{1}{8}$ inch for most popular sizes. Now, using a hacksaw, cut a slot down into this hole. Your jig should look like the drawing in Fig. 3. To use this jig, slip it over the end of the shaft, then pinch it firmly in a vise. The slot allows the jig to hold the shaft firmly, preventing loss of tension. The old fitting may then be twisted off with pliers if it is swedged (pressed) on, as most are. Turn it in the direction of the twist of the outer strands of the shaft, and it will unscrew easily in most cases. The new fitting may then be installed, and sweated on with solder, being sure to make a good tight clean joint, as it is under a good deal of strain.

Some remote control heads had the volume controls and switches mounted in the heads themselves, connected to the sets with shielded cables. These caused some difficulty, in a few models, giving an extremely high buzz level. This was traced to the fact that the grounding of the control head and switch was not heavy enough. The current drawn by the set was traveling in the shielded braid covering the very sensitive

volume control circuit. This caused a buzz voltage to be picked up by the volume control wiring. The cure for this was the addition of a very heavy grounding strap between the control head case and the set chassis. A battery ground strap, one inch wide, of very heavy wire braid, was used. This stopped the noise.

If the set has pushbutton tuning, the push buttons themselves are mounted in the control head, connected to the automatic tuner mechanism inside the set by a multi-conductor cable. The actual operation of tuning is done by this mechanism; only the push buttons are in the control head.

Auto Radio Speakers

The speakers used in early auto radios were of many different sizes and shapes, but all of them were electrodynamic speakers, with a 6-volt field coil. This field consumed over one ampere of current. These have been replaced in all sets now by the permanent-magnet or PM dynamic, which uses no field current at all. A great number of sets today use the same speaker, a 6 x 9 oval PM, which simplifies the parts-stocking problem. Many of the cars using separate speakers have mountings for this oval speaker: Ford, Chrysler, Plymouth, Chevrolet.

Some cars have a provision for a rear-seat speaker. This is a PM unit, usually a 5-inch round speaker, located behind the rear seat back, on the package tray, between the seat and the rear window. The trays are covered with a heavy fiberboard, usually supported underneath by a stamped metal framework. In this framework there will be found a cutout for the speaker, requiring only the cutting of the fiber with a knife in order to install a speaker. Only two wires are required, and these are usually brought up to the set under the floor mats on the left side of the car. Many sets have plugs and sockets for rear seat speakers incorporated in their design. Some even have special volume controls already mounted, to allow fading in of the rear seat speaker, playing either the front speaker, the rear speaker or both simultaneously. If there is no provision for it on the set, the extra speaker may be connected with a special switch, made for the purpose, which is mounted under the dash. The voice coil lead from the set speaker is brought out of the case to this switch, and the rear speaker connected here also. The switch has three positions, "Front," "Rear" and "Both." Small resistors are generally used, as pads, across the switch, to equalize the volume levels when speakers are switched into and out of the circuit. Otherwise, when only one speaker is used, there would be a sudden blare of sound.

The speaker itself accounts for a good bit of the trouble found in auto radios. Due to the difficult conditions under which it must work, it suffers

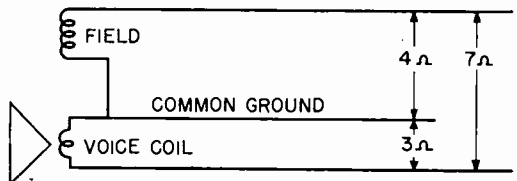

FIG. 4. Identification of wires in 6-volt dynamic speaker, by using ohmmeter. Field coil is always exactly 4 ohms, voice coil dc resistance is usually from 2.5 to 3 ohms.

from a lot of troubles, such as warped or dragging voice coils, open voice coils, and damaged cones. In cases where the vibrator is working, but there is no sound at all, the speaker should be checked first. Voice coil leads from the frame to the cone itself are made of very fine wire, just as in any speaker. Due to the high levels used in automobiles, these will often break. If the cone is all right, and the voice coil not dragging, these leads may be replaced by using leads taken from salvaged speakers or any other kind of very flexible wire. They are fastened to the cone itself through a small metal grommet. The leads may be unsoldered here, using a very small iron, and replaced with new ones. Many intermittents may also be traced to these leads. They have a fiber core, with a very fine wire woven around it. If the wires break, the core will keep the wire in place, allowing it to make intermittent contact.

There is one more problem, encountered in the older sets, using separate 6-volt dynamic speakers. They use three wires, the 6-volt field, the voice coil, and ground. If these are misconnected, with the 6 volts going through the voice coil, it is possible to burn out the small wires of the voice coil in a short time. Many sets have a series of pin-jacks on the sides of the case, for the connection of these wires. If the speaker is mounted, so that it cannot be seen, the wires may be checked out with an ohmmeter. Measure the resistance between the three wires. The field resistance will be exactly 4 ohms; the voice coil will measure about 3 ohms. Therefore, if you can find the pair of wires with 4 ohms across them, you have the field and ground. Which is which, though? Measure from one of these to the remaining wire, which has to be the voice coil. This is illustrated in Fig. 4. You can check this, by listening closely to the speaker as you apply the ohmmeter prods; if this is the voice coil, you'll hear a very faint click from the speaker. If this measurement gives you around 7 ohms, you have the field and the voice coil, and the wire you just laid down is the ground. If you get only 3 ohms, you have the voice coil and ground, and the remaining one is the field. One certain test is to hook them up to the set, and turn it on. If you hear a loud buzz in the speaker *immediately* upon turning the switch, turn it off.

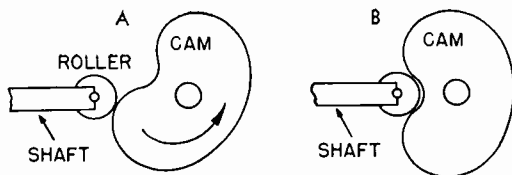

FIG. 5. Illustrating action of simple "camtuner," used in auto radios. The shaft, connected to the push button, causes the cam to turn in the direction of the arrow, in A, turning the tuner itself, which is driven by the cam shaft. In B is shown the finish of the operation: the roller has turned the cam until it reaches the "bottom" of the notch in the cam; one cam is used for each push button.

You have the voice coil connected to the field. Reverse the wires from voice coil and field, and try again. If there is no sound until the set warms up, and then it is very weak, reverse the wires from field and ground. Remember, if you hear that buzz the instant the set is turned on the voice coil is connected to the field and will be damaged unless the set is turned off immediately.

Automatic Tuners

Quite a number of auto radios have been made using some form of automatic tuning. These allow the driver to tune the set by merely pushing a button, without taking his eyes off the road. Some have even used foot switches, like the familiar dimmer switch, to actuate the tuner. There are many variations in actual design, but only two or three in basic principles.

There are only three major groups of automatic tuners: The "manual" or semi-automatic, which moves the tuner to a preset location when a push button is depressed; the fully-automatic tuner, which is started by the push button, and actually tunes itself; and finally, the "Signal-Seeking" tuner, which is both electrically driven and electronically controlled.

The simplest of these, of course, is the manual tuner. In this type, a variable capacitor is generally used, with an extension on the shaft. Mounted on this shaft are several cams; push buttons engage these cams and cause the cams to assume a preset position. The action of the shaft and cam are shown in Fig. 5.

Because of the tremendous number of variations of tuners in use today, we shall not attempt to give you details on any one particular type. We can confine ourselves to the basic operating principles of each type, and let you look up the details in the instruction manuals for the set involved. This would be necessary in any event.

The cams are fastened to the tuner shaft by a

friction-fit set of spacers; a locknut on the end of the shaft is loosened for adjustment, then tightened to hold the cams in place. To set this type up on the different stations, the locknut is loosened, and the set tuned to a station. Holding the tuning knob to prevent it moving, the first push button is depressed; this sets the first cam. This is repeated for each push button, retuning of course between push buttons, and the locknut is then tightened to hold the cams.

As we said, this is about the simplest of the automatic tuners, and very little trouble is found in them. Most of this is mechanical, due to bent arms, lack of lubrication, etc., and can be easily remedied. Most automatic tuners, of whatever type, will consist, at first glance, of a bewildering array of arms, levers, pins and other gadgets, the function of which appears impossible to determine. However, each one is placed there for a definite purpose, and a little careful study will usually determine what that purpose is.

The biggest enemy of the automatic tuner is dirt and grease, which are plentiful in the auto radio. The very first step in any repair to an automatic tuner would be a thorough cleaning. Wash out all dirt and old grease using carbon tetrachloride or other harmless solvent, and lubricate, very sparingly, using a cream lubricant, such as "Lubriplate" or a similar product. Check for binding or dragging between the various parts, and most of them will work perfectly again. Remember, all tuners must be thoroughly clean before they can be expected to work properly. The tuning mechanism itself, whether a capacitor or a set of slugs, must move freely in its slides or bearings before any decent results can be expected.

Many of the auto tuners use slug tuning. With this type, the motion of the tuner is back and forth, as contrasted to the rotary motion of the capacitor tuner. The slugs themselves are mounted on a carriage, a strip of fiber with a small metal frame for added rigidity, which holds the ends of the adjusting screws. This carriage slides back and forth in guides or tracks along the sides of the tuner assembly so that the position of the slugs with respect to the coils may be changed. The mechanical assembly of this type of tuner is shown in Fig. 6. This calls for a difference in the mechanism of the mechanical tuner drive, due to the difference in motion. Therefore, most slug tuners use the same system, or variations of it. The carriage is pulled all the way to one end of its travel by the push button, then released. It is pulled back toward the other end by a spring, until it strikes a preset stop, which halts the carriage in the right place to receive a given station.

Some tuners pull the carriage with a solenoid, actuated by the push-button switch; some do the same thing manually. The principle is ex-

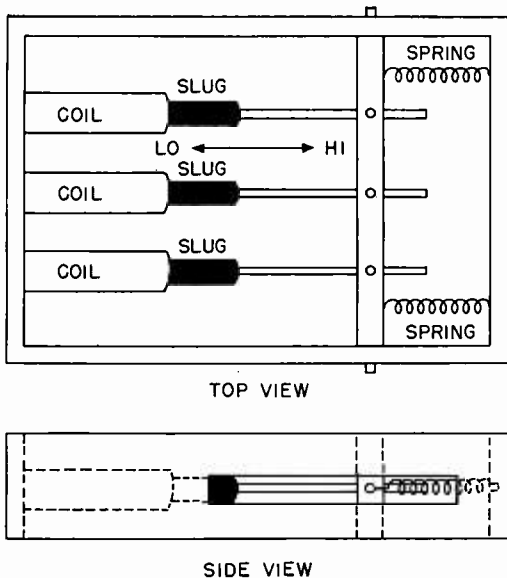

FIG. 6. Typical "slug tuner" (permeability type) as used in automatic tuning auto radios. This is tuned by sliding powdered-iron "slugs" in and out of the coils, varying their inductance. The slugs are held by long thin screws, so as to be adjustable for tuning purposes. The screws are fastened to a carriage, which is a strip of insulating material.

Many different methods are used to drive the carriage back and forth, varying with the make of set, but all use this basic system. The carriage is pulled toward the low-frequency end (slugs in) by the tuner mechanism, then pulled back by the two springs shown on the carriage.

actly the same in either case. The push button moves the carriage to the end of its travel, at the same time setting a stop in its return path.

Some Ford and Motorola radios have used a novel variation of this type. The stops are mounted on a cylindrical frame, or "turret," which revolves 60 degrees every time the tuner is operated. The stops are mounted on long screws running longitudinally on the turret. Five of these are for the automatic tuner, the sixth, with a much higher-pitched thread, is the manual tuning drive, which is moved by the tuning knob. In use, the carriage moves back and forth, while the turret revolves, bringing a different stop into place each time it operates.

Many GM-Delco sets used another variation; the push buttons operated cams, similar to those described earlier. The mechanical drive was accomplished by a worm and gear, driven by the manual tuning knob. In addition to this, a clutch

is installed between the manual drive and the main shaft, to eliminate the drag, by releasing the clutch every time the push buttons are operated. If this type shows signs of slippage with manual tuning, pry the clutch plates apart and wash out with carbon tetrachloride to remove the grease. If it still slips, loosen the screws holding one clutch plate and move it closer to the other. This will increase the tension.

The Signal-Seeking Tuner

A development of recent years, first appearing in Cadillac and other high-priced cars, is the really "full-automatic" tuner, known as the "Signal-Seeking" tuner. This operates as follows: when the operating bar is depressed once, the tuner begins "seeking"; that is, moving from one end of the dial to the other. When the tuner crosses a station, which is strong enough, it stops. During its travel, the audio output of the set has been muted by a pair of contacts on the tuner that short out the speaker voice coil. This eliminates the noise, etc., which would otherwise be heard while the tuner is operating. When it stops, this short is released, and the set plays.

In action, the cycle is as follows: When the button is pushed, the tuner carriage is pulled slowly to the high end of the dial by a spring. As it reaches the end of its travel, the tuner carriage is released and a solenoid pulls the tuner rapidly back to the low end of the band.

The drive spring works through a special gear train, which slows down the otherwise rapid travel to the speed necessary for stopping on a station. Also coupled to this gear train is a small plastic fan or paddle-wheel. This acts as an "air-brake" while the tuner is traveling, preventing it from going too fast. Mounted near this paddle-wheel is a relay, with its coil connected in the plate circuit of a tube. The armature or moving part of the relay has a small hook on the end that drops into the blades of the paddle-wheel, causing the tuner to stop when the relay is not energized. A simplified diagram showing the action of this type of tuner is outlined in Fig. 7.

The coil of the relay is in the plate circuit of one section of the twin-triode tube. The first section of this tube has its plate directly coupled to the grid of the second section. In this way the first section acts as an amplifier stage to insure sufficient current to operate the relay in the plate circuit to the second section.

To start the tuner running the plate of the second section of the dual-triode is shorted to ground. This energizes the relay and lifts the hook on the armature out of the paddle wheel which allows it to turn. At the same time a contact on the relay armature changes the bias on the first section of the dual triode so that the

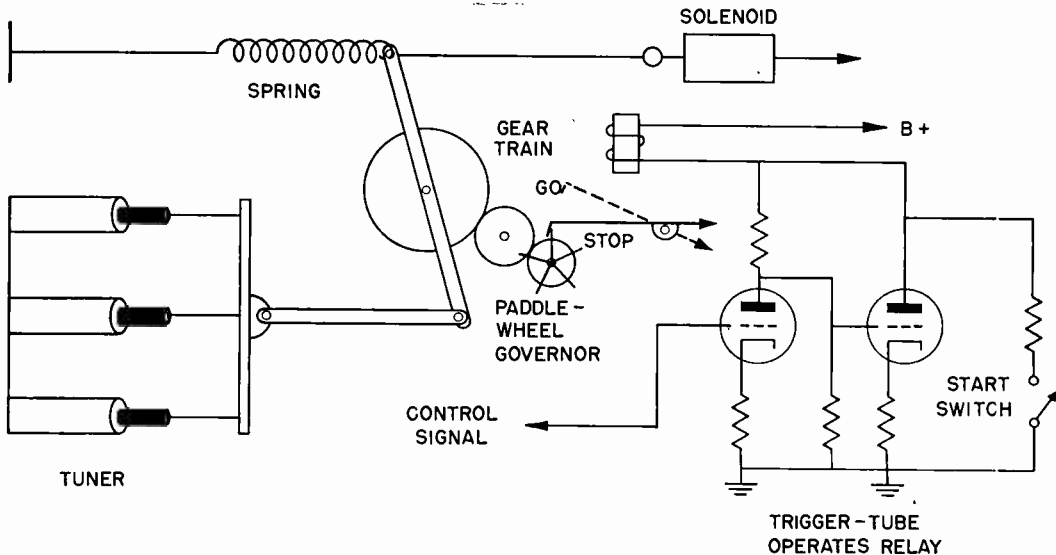

FIG. 7. Simplified schematic of action of "Signal-Seeking" tuner. There are several variations from this, but basic action is the same. Tuner is pulled all the way to the right by the solenoid, when the actuating switch is pushed: it then returns slowly to the left, pulled by the spring, upper left: the speed is held down by the gear train and the governor. When a station is crossed, the AVC voltage causes the trigger tube to operate the relay, dropping the "jammer" into the paddle wheel, stopping the tuner on the station. In actual circuits, this is much more complicated, but this is the basic action.

relay will be held closed. When the tuner crosses a station loud enough to be usable, a pulse of signal voltage developed by the i-f stages is applied to the grid of the first section of the dual triode. This pulse is positive-going and after amplification drives the second section to cut-off. Cutting off the bias of the second section of the tube allows the relay to open, and drops the armature hook into the paddle wheel so that the tuner stops on the station. If the tuner is not stopped by a signal before reaching the high end of the band, the solenoid is energized and the tuner assembly is drawn rapidly to the low end of the band at which point the solenoid circuit is broken and the spring drive pulls the tuner back down through the band.

Trouble with this type of tuner, and with other

— n r i —

Attention C. R. Lowe, Urgent!

We have received your Postal Money Order for \$10, issued April 4, 1956 by the Air Force Postal Service, Seattle, Washington. It came in an Air Mail envelope postmarked April 25, 1956, North Pole RUR. Sta., Fairbanks, Alaska. Please identify yourself by address and student number, and tell us what this payment is for.

types of signal-seeking tuners, may be found in either the set or the tuner. Obviously, mechanical trouble in the tuner itself will ruin its performance, but so will troubles in the set such as power supply failure, weak tubes in i-f amplifiers, or antenna troubles. If the signal-seeker does not receive a signal strong enough to actuate its circuits, the tuner is going to keep on "seeking" until one is found! or in case the set is bad, until it is turned off or repaired.

Inasmuch as there are on the market now at least three different types of this tuner, and more to come, your best source of information is the schematic diagrams of the tuner itself. Variations will be so wide that it would be impossible to give you any detailed information on it here.

— n r i —

Testing

The electrician was puzzled. "Hi!" he called to his assistant, "put your hand on one of those wires."

The assistant did as he was told.

"Feel anything?"

"No."

"Good!" said the electrician. "I wasn't sure which wire was which. Don't touch the other or you'll drop dead."

—Williams Words

The Famous Model 260 Simpson AC-DC VOMA

Only
\$38.95

Completely
Portable
No AC Power
Required

20,000
Ohms-Per-
Volt on DC
1,000 Ohms-
Per-Volt
on AC

Measures
AC-DC Volts
AC Output
Decibels
DC Current
Ohms

\$8.00 Down
\$5.50 Per
Month

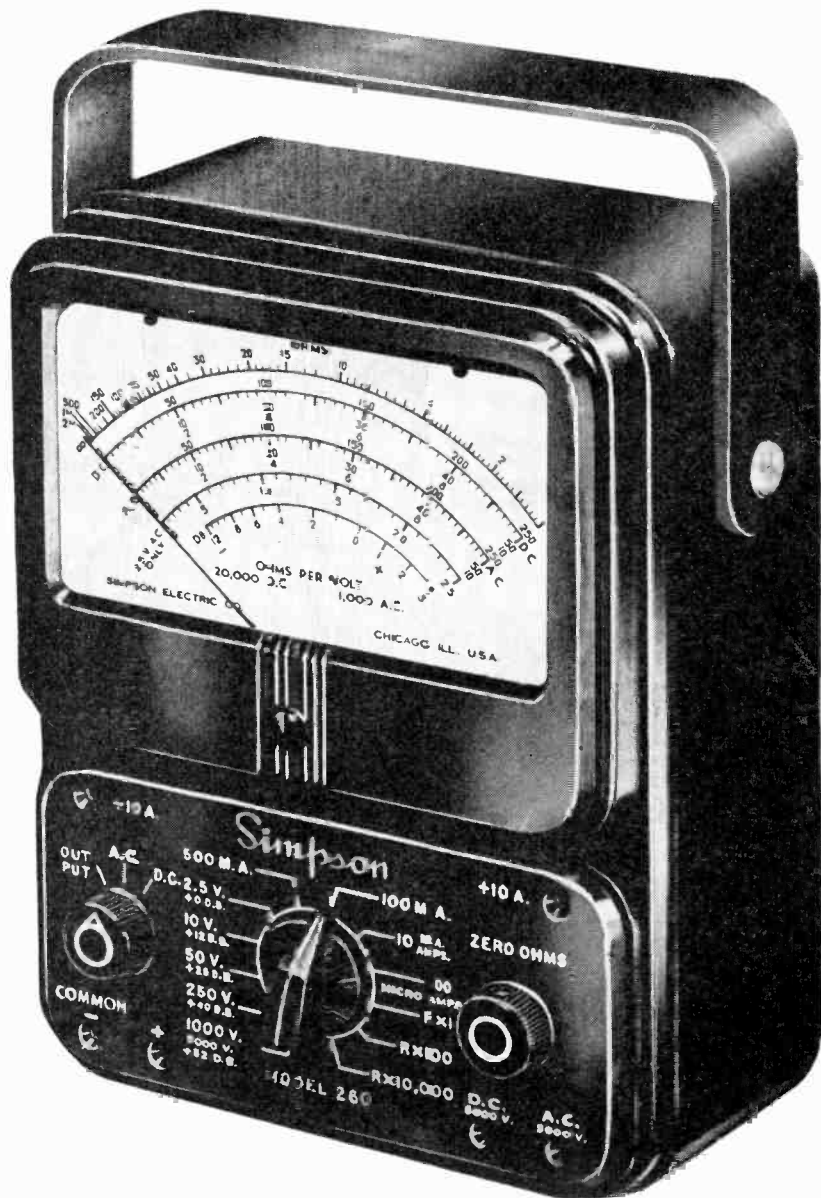

NOW AVAILABLE THROUGH NRI SUPPLY DIVISION

THE very popular Simpson Model 260 Volt-Ohm-Milliammeter is a moderately-priced instrument for the man who wants simplicity of operation and complete portability. Many servicemen find it advantageous to own an instrument of this type in addition to a Vacuum Tube Voltmeter.

For Radio and Television Servicing

D.C. sensitivity of 20,000 ohms-per-volt is adequate for practically all Radio and TV measurements. Note the Model 260 measures micro-amperes, milliamperes, and amperes, something most Vacuum Tube Voltmeters do not measure.

Completely Portable

Saves time, especially on service calls. No need to plug instrument into power line. (Long lasting batteries contained within the instrument are used when measuring ohms.) Very handy when checking auto radios, etc., where a.c. power is not available.

Over Half a Million Now in Use

This is the instrument which has led the field in popularity for many years. Used widely in the Armed Forces and Industry, as well as by Servicemen the world over. NRI is pleased to offer this quality instrument to our students and graduates at regular Dealer's Net Prices.

ACCESSORIES

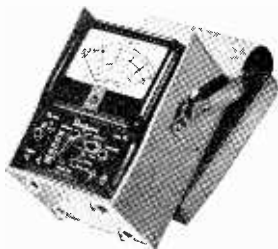

Ever-Redy Carrying Case

Saves your time! Large, one-piece lid folds back to expose meter and selection switches... ready for instant testing. Made of rugged Vinyl. For Model 260. Price \$8.75.

25,000 Volt DC Probe for TV Servicing

For use with Model 260. Extends d.c. ranges up to 25,000 volts. Complete with instructions. Price \$9.95.

29 RANGES

AC	Volts	DC	Volts
2.5	250	2.5	250
10	1000	10	500
50	5000	50	1000

DC Current		Ohms	
100 micro-amperes		O-2K (12 ohms center)	
10 milliamperes		O-200K (1200 ohms center)	
100 "		O-20meg. (120K center)	
500 "			
10 amperes			

Output		Decibels	
2.5	50	-12 to +55 DB	
10	250	(five ranges)	

Handsome black molded Bakelite case. Size 5¼" x 7" x 3½". Large, easy-to-read 4½" meter scale. Net weight, 3½ lbs. Shipping weight, 6 lbs. Shipped by Railway Express, shipping charges collect. Operating instructions and test leads included. Price below is Dealer's Net Price. Covered by standard RETMA warranty.

MODEL 260 ORDER BLANK --

National Radio Institute
16th & You Sts., N.W. Washington 9, D. C.

I enclose \$..... (certified check, money order or bank draft) for which send me, by Railway Express, charges collect, the items I have indicated in the box on the right.

	Price	Write price here and add this column
Model 260 Simpson VOMA, including test leads and operating instructions	\$38.95	
25,000 Volt Television Probe	9.95	
Eveready Neolite Carrying Case	8.75	
(If you live in Washington, D. C. add 2% D. C. Sales Tax)		
Total amount enclosed		

Tell me how I can buy this VOMA on monthly terms.

Name Student No.

Address

City Zone State

Express Office
(Please print name and address)

Graduate David P. Cressey, of Stockton, California Wins \$1,000 for Most Original Decoration



Above is shown the winning store front of the Cressey Radio and TV Shop. The contest, sponsored by RCA was for the most original decoration depicting the new Silverama picture tube. The contest was held from California to the Mississippi river. David Cressey, an NRI graduate, placed first among over 10,000 entries, and received a \$1,000 bond for his prize-winning store-front decoration. Cressey's Radio and TV Shop is located at 1912 North Wilson Way, Stockton, California.

Last December, the RCA Victor Company offered \$1,000 to the dealer who came up with the most original decoration depicting the new Silverama picture tube. The contest was held from California to the Mississippi river. David Cressey, an NRI graduate, placed first among over 10,000 entries, and received a \$1,000 bond for his prize-winning store-front decoration. Cressey's Radio and TV Shop is located at 1912 North Wilson Way, Stockton, California.

A part of Graduate Cressey's formula for success follows:

"I opened my shop in June, 1955, before I had completed my NRI course and received my diploma. However, long before I opened my business,

— n r i —

Radio-TV Technician Wanted In Taylor, Texas

The Kincl Hardware, 200 West Second Street, Taylor, Texas, is interested in hiring a Radio and TV serviceman. He should be able to handle all types of service and installations. Will consider graduate or advanced student. Write to Mr. Lewis A. Kincl, Manager, at the above address.

Twelve



Walt Lessing, District Field Representative for RCA, (left), congratulates David P. Cressey on being the lucky winner for the \$1000 bond. From left to right in the above picture are Walt Lessing, Charles Berkaw, Regional Manager from RCA, Pat Dunlap, Manager of Dunlap Wholesale Radio, NRI Graduate David P. Cressey, who won the RCA \$1000 bond, and Ray Mitchell, also of Dunlap Wholesale Radio.

I was repairing radios and television sets on the side, after working hours. I found the experience helpful and also the extra money went into equipment.

"I opened here in a town in which I had never lived. By advertising and word of mouth, my business grew. Last month my business increased to the point that I had to have help. I also have a salesman working for me on the outside, as I am now a dealer for Packard-Bell, Raytheon, VM, and Motorola. My business is profitable and I am independent.

"I had never touched a radio or television as far as servicing goes. Now, thanks to NRI, I am operating my own business. I am a booster for NRI as it has done so much for me."

— n r i —

Radio-TV Serviceman Wanted In Glendive, Mont.

Here's a chance to work for an NRI Graduate who is well established in the Radio business, and who is now expanding into TV. Will consider either a student or an experienced technician. If interested, write direct to Angelo Tomalino, TOMALINO RADIO SERVICE, 303½ N. Merrill, Glendive, Montana.

Career Job Opportunities with International Business Machine, Field Engineering, Kingston, New York

NRI has been requested by the Manager of IBM Field Engineering Employment to notify our students and graduates of employment opportunities which exist for electronic technicians and engineers. A booklet entitled "A Career for You" is available for the asking from Field Engineering Employment, Department 404, IBM Military Products Division, Kingston, New York.

IBM is assisting the U. S. Government in the defense of our country by designing, building, and maintaining large-scale electronic computers. The Field Engineering branch of IBM has the responsibility for installation and maintenance of these computers at various locations throughout the United States and Canada. Openings exist for several thousand Field Engineers. These men must be skilled technicians or electronic engineers, and before assignment will receive up to nine months additional training on

the digital computer system made by I B M.

Training will be given at the IBM plant in Kingston, New York. Engineers receive approximately nine months training and technicians approximately six months training. IBM pays normal travel expenses to Kingston, plus a living allowance over and above training salary, and moving expenses after training has been completed. IBM has substantial employee benefits.

If you are looking for a career job with a large, well-established company, write for further information to: Field Engineering Employment, Department 404, IBM Military Products Division, Kingston, New York. It will be helpful to give a brief summary of your education and experience at the time you write. Be sure to mention *National Radio-TV News*.

— n r i —

— n r i —

Unusual Employment Opportunities Requiring Electronics Background

A number of interesting positions are open for mature, well-adjusted people who find working with others challenging and interesting, over and above the technical requirements of electronic work. Applicants should be well grounded in basic electronic theory. Advanced NRI students or graduates would likely have the required background. Some college training, not necessarily in electronics, would be helpful, but is not necessary. Amateur radio experience and practical experience, again, would be helpful, but are not absolutely necessary. Applicants must have a high school education and U. S. Citizenship is required.

usual in that the man, himself, is just as important as his technical training and background.

Starting salaries range from \$4,500 to \$5,500 per year. Junior positions also exist with starting salaries from \$3,600 to \$4,500 per year. Applicants for Junior positions should have high school education, good appearance and personality, and know basic electronic theory. These applicants will undergo on-the-job training on basic electronic repair work. Should be willing to travel overseas at some time. Interested applicants should write a complete letter of application giving name, date of birth, address, telephone number, complete military history, non-military training, employment background, and mentioning amateur or commercial licenses held, if any.

These are not routine jobs. The individual will be called upon to improvise and has ample opportunity to use independent initiative in solving problems connected with Radio or Electronic applications. Individuals should be willing to serve overseas at some time in the future and must pass physical examinations. These jobs are un-

These letters of application will be forwarded by NRI to the prospective employer and will be acknowledged by that organization within a reasonable time.

— n r i —

— n r i —

Would You Like To Work For An NRI Graduate In Lansing, Michigan?

An opening exists for a Radio-TV serviceman with the Modern TV Center, 2017 E. Michigan Avenue, Lansing, Michigan. This progressive Radio-TV Sales and Service organization is owned and operated by NRI Graduate Lyle D. Esch. Letters of inquiry should be directed to Mr. Esch. This sounds like an excellent opportunity for a beginner who can "catch on quickly."

Communications Technician For Radio Propagation Field Station

Opening exists for Communications Technician having three or four years experience. No license required. Starting salary at about \$3,415 to \$3,617 per year, depending on experience. Letters of application should be directed to Mr. Edward Wiewara, Field Station Chief, North Atlantic Radio Warning Service, Box 178, Fort Belvoir, Virginia.

High-Fidelity Audio Power Amplifiers

By JOHN G. DODGSON

NRI Consultant



John G. Dodgson

THE amplifier is often considered the heart of a high fidelity system, since the amplifier is in the center of the system between the input signal from the phonograph, tuner, or tape and the loudspeaker. Furthermore, it is in this section of the high fidelity system that we control the tone and loudness of the sound.

The input to a high fidelity amplifier from the signal source, whether it be a cartridge, tuner,

or tape, is a very low voltage signal. Since loudspeakers are power-operated devices it is necessary to amplify this low voltage signal to a high voltage level and then to amplify or change this high voltage signal to a sufficient power to operate the loudspeaker.

In order to obtain sufficient output power with low distortion it is necessary to use a push-pull output stage in high fidelity amplifiers. A typical push-pull stage with a simple phase inverter transformer is shown in Fig. 3.

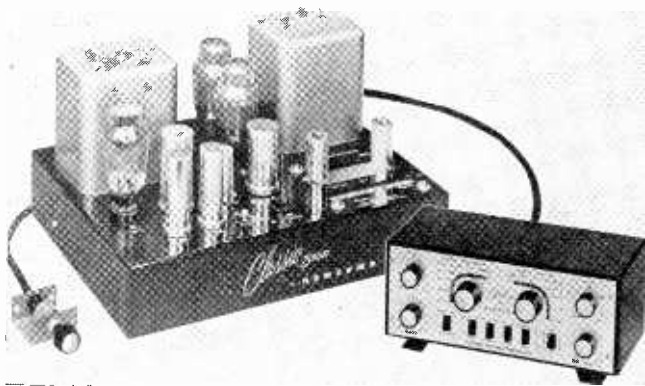

Courtesy Newcombe Audio Products Co.

FIG. 1. Many of the highest quality amplifiers such as this Newcombe 2500-R are built in two sections with the power amplifier and power supply on the larger chassis and the preamplifier-control unit on a smaller chassis. Such amplifiers are capable of extraordinary response. This 25-watt amplifier, for example, has a frequency range from 10 to 100,000 cycles at only .01% distortion at 10 watts output which is well above the average playing level.

Phase Inverters

For many years the transformer-driven output stage was used employing triodes or beam power tubes with the addition of negative voltage feedback. The greatest improvement to such a stage was the elimination of the phase inverter input transformer and the use of vacuum tubes as phase inverters. Such a basic stage is shown in Fig. 4. Notice that the driver tube VT1 feeds the grid circuit of power output tube VT2. The grid resistance in this stage is split and a portion of the signal voltage is applied to the grid of VT4. Since this tube inverts the signal 180 degrees (as all amplifier tubes do) the signal fed to VT3 is the same but opposite in phase to that fed to tube VT2 giving push-pull operation. The greatest advantage of the resistance-coupled inverter stage is lower harmonic and intermodulation distortion and a wider frequency range as

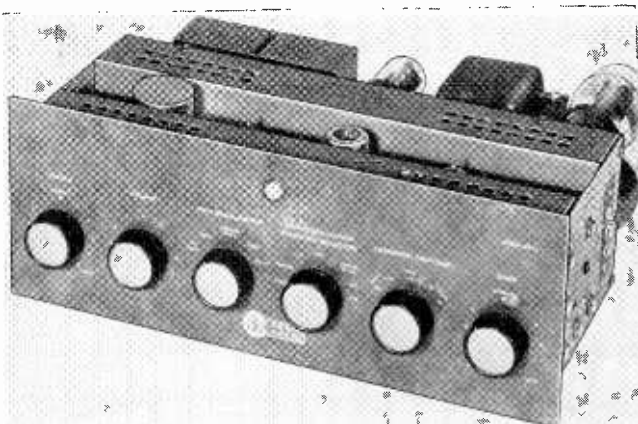

Courtesy David Bogen Co., Inc.

FIG. 2. The usual High Fidelity Power Amplifier such as this Bogen DB15 has, on the same chassis, a preamplifier and controls.

while resistors R7 and R6 are the grid resistance for tube VT3. Resistor R6 is then in both grid circuits which are fed the same signal but of opposite phase, causing degeneration.

When a signal is amplified by VT1 a portion of it appears at the R5-R6-R7 junction point and is consequently fed to and amplified by tube VT4. The amplified signal is applied to the grid resistance of VT3-R7-R6. Thus a portion of this amplified signal appears at the R5-R6-R7 junction point and tends to cancel out the first signal. If it does, circuit operation will cease. Therefore resistors R5, R6, and R7 are chosen according to the gain of tube VT4 so that the output voltage of VT4, which is applied to the grid of VT3, is equal to the output of VT1, which is applied to the grid of VT2, achieving balanced

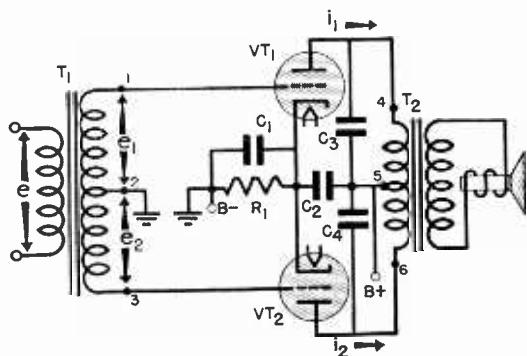

FIG. 3. A simple transformer fed push-pull triode power amplifier.

well as reduction of magnetic coupling, hum pickup, weight, cost, etc.

Fig. 5 illustrates a cathode follower, or as it is sometimes called, a cathodyne phase-splitter. In this circuit, equal cathode and plate resistors are used, so the signal voltage in the plate-to-cathode circuit is effectively divided. Output is then obtained from the circuit as shown in the illustration and since the plate and cathode circuits are out of phase equal signals of opposite phase are available to feed the output tubes.

The "floating paraphase" inverter shown in Fig. 6 is very similar to the basic phase inverter shown in Fig. 4. However, the floating paraphase has the additional advantage of self-balancing. In this circuit the phase-inverter grid is fed from the junction of resistors R5, R6, and R7. Resistors R5 and R6 form the grid resistance for tube VT2

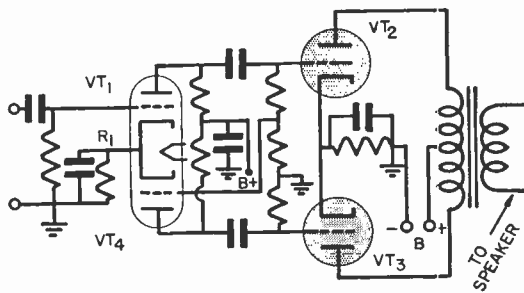

FIG. 4. A vacuum tube phase inverter.

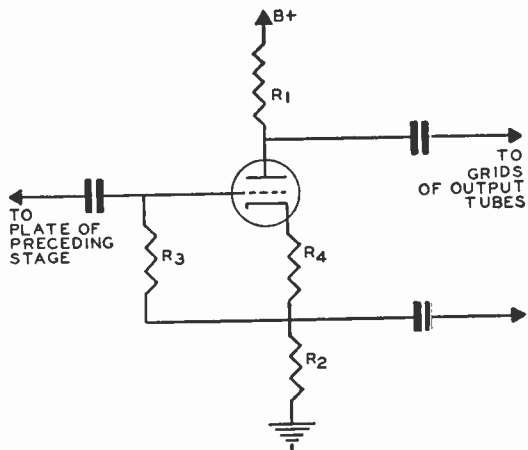

FIG. 5. The cathode-follower or cathodyne phase splitter. R1, R2 Plate and cathode load resistors; R3 Grid resistor; R4 Bias resistor.

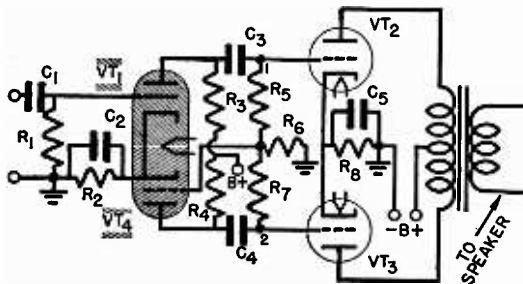

FIG. 6. The Floating-Paraphase phase inverter.

push-pull operation; and so that the portion of the output voltage of VT4 that appears at the R5-R6-R7 junction does not completely cancel out the initial signal.

In practice this isn't too difficult to obtain providing the gain of VT4 is known. The home experimenter, however, will probably have to use the "cut and try" method since resistors R6 and R7 affect the gain of VT4.

All three of these simple phase inverters are now used in high fidelity amplifiers. In addition there are several other versions such as the "long-tailed" pair shown in Fig. 7 and the "Kappler" shown in Fig. 8. Notice the similarity of these circuits.

In the "long-tailed pair" phase inverter the input signal is applied to the grid of VT1 and the amplified output signal of the tube is fed through coupling condenser C2 to one of the output tubes. Tube VT2, a grounded grid amplifier by action of condenser C1, receives its signal from the common cathode resistor R5. Since the grid resistors R3 and R6 are connected to the junction of the two cathode resistors (R4 and R5) only the voltage drop across resistor R4 provides bias for the stage. Resistor R4, causing degeneration, reduces distortion and stabilizes the stage.

The Kappler circuit is a unique combination of other circuits. The first triode VT1 directly feeds the second triode grid. Output can then be taken from the low impedance cathodes and since both cathode resistors R2 and R3 provide degeneration, distortion is negligible.

The Williamson Amplifier

For many years there was little interest in high fidelity reproduction except by a few hobbyists and little was done to improve these basic audio stages or develop new methods. However, five or six years ago a new type of amplifier appeared called the "Williamson" after its inventor, D. T. N. Williamson. A basic Williamson amplifier stage is shown in Fig. 9.

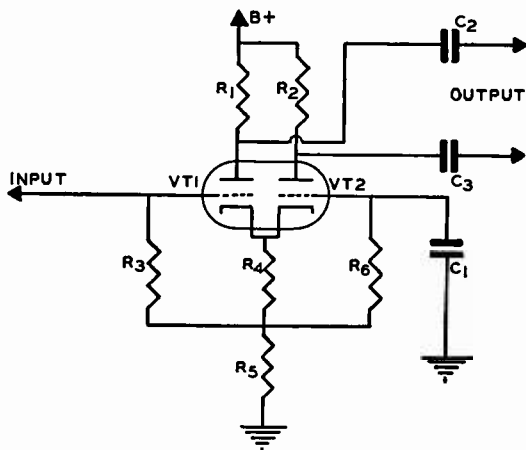

FIG. 7. "Long-Tailed Pair" phase inverter.

Notice the difference between this amplifier and that shown in Fig. 3. A cathode follower type phase splitter is used and the first driver is directly coupled to the phase splitter. A push-pull driver stage is used between the phase splitter and the power output tubes. The power output circuit itself uses beam power tubes connected as triodes and considerable feedback is employed between the output transformer secondary and the first driver stage.

This Williamson amplifier sparked a new interest in high fidelity because of its exceptional qualities of extremely wide frequency response at very low distortion. However, this amplifier, too, had its limitations. For example, due to the cathode follower type phase splitter unbalance was obtained at very high frequencies due to the differences in interelectrode capacities between the grid and plate and the grid and cathode.

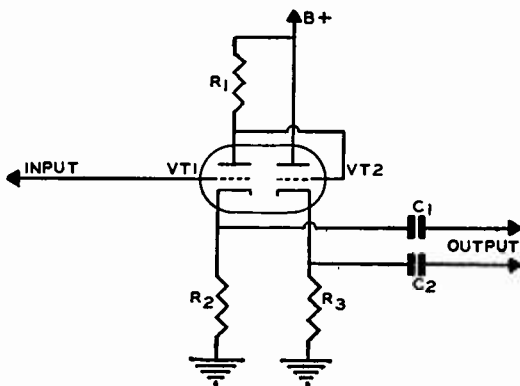

FIG. 8. The Kappler Circuit.

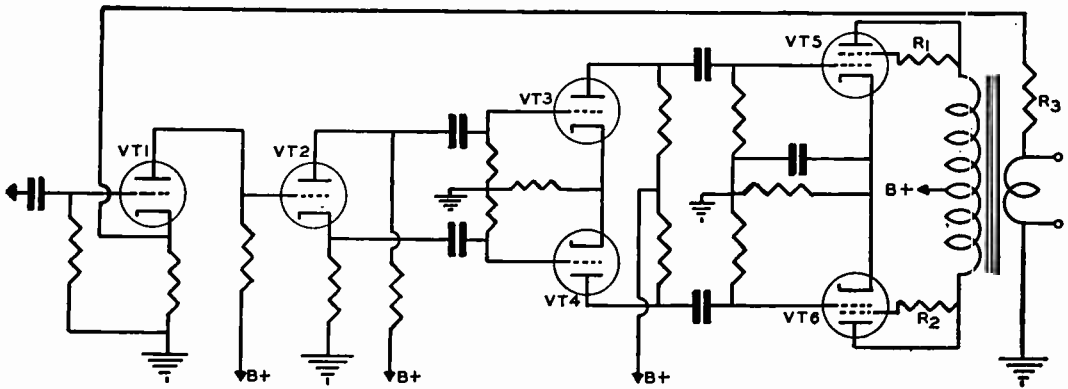

FIG. 9. A basic Williamson circuit. VT1 Voltage Amplifier; VT2 Phase inverter; VT3, VT4 Push-pull drivers; VT5, VT6 Push-pull triode connected power output tubes; R1, R2 Suppressor resistors to prevent parasitic oscillations; R3 Feedback resistor.

Another fault was the limited power output obtained with the triode-coupled tetrode tubes.

Three or four years after the initial announcement of the Williamson amplifier, two audio engineers, D. Hafler and H. I. Keroes, improved the Williamson amplifier as shown in Fig. 10. This improvement in the amplifier somewhat stabilized it and greatly improved the frequency response and power output. This particular type circuit is very popular today partially because of the recent development of high quality output transformers at reasonable prices.

It is not unusual for such an amplifier to have a frequency response from 2 to 200,000 cycles per second ± 1 db at normal listening levels with harmonic distortion well below 1%. It should be pointed out that there are many variations of the basic Williamson circuit. The labeling of an audio amplifier as a "Williamson type" does not necessarily indicate high performance. Good response depends on the proper choice of component values and the quality of the output transformer.

Power Output Tubes

Along with the development of amplifier circuits there has also been a redesign of tubes especially built for audio purposes. In modern amplifiers two type tubes seem to be most popular.

In amplifiers up to 12 watts the type 6V6 or its miniature equivalent, type 6AQ5, is generally used. For higher power amplifiers, the type 6L6 is most popular although some amplifiers have used type 1614 and type 807 tubes.

Another very popular type tube, from England, is the type KT66 which is a direct replacement for the type 6L6. This type tube was developed

to replace the type 6L6 and has better audio characteristics. After the introduction of this tube the type 5881 was developed in America with similar characteristics. Recently some higher powered tubes, such as the 6550 and the 6CA7, have been developed. These are high-powered versions of the 6L6-KT66 family for use in 50 to 100 watt amplifiers.

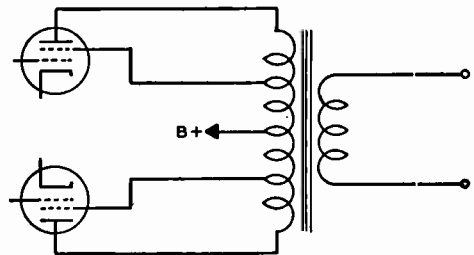

FIG. 10. Ultralinear alteration of Williamson amplifier.

So far we have discussed several different types of amplifiers used today in high fidelity circuits. The basic amplifier shown in Fig. 4 using pentodes or triodes, the Williamson amplifier shown in Fig. 9, and the ultra-linear Williamson type shown in Fig. 10. Actually, the triode type amplifier shown in Fig. 4 is becoming obsolete since recent improvements in audio output transformers enable a beam power type circuit to have extremely low distortion with a more useful power level.

In the last few years several new amplifier circuits have been developed and will now be discussed. In most cases the new circuits have been patented and therefore only the company holding the patent is producing the type amplifier. Of course, when the patent rights run out, un-

doubtedly other manufacturers will produce similar amplifiers.

Bridge-Circuit Output

Fig. 11 shows the basic circuit diagram of a new bridge-circuit type power output stage developed by A. M. Wiggins and used in Electro-Voice "Circlotron" amplifiers.

This simplified circuit shows batteries where power supplies would actually be used. Notice in this bridge circuit that the dc plate current of each tube passes through both power supplies without going through the windings of the output transformer, since the circuit is a balanced bridge under no signal conditions.

This bridge consists of the two output tubes and the two power supplies, B1 and B2. The output transformer is connected across the bridge between the cathodes of the tubes and is center-tapped to establish the grid-to-cathode circuit through the bias supply B3.

To simplify the circuit, triodes are shown in the diagram although beam power tubes are used in the commercial amplifiers.

As can be seen in the diagram the entire total primary windings are presented as a load to each tube since this winding is essentially connected from the plate to cathode of each tube. One-half of the load is in the cathode circuit while the other half is in the plate circuit. Also, the plate load of one tube is the cathode load of the other and vice versa. Each tube therefore "sees" the same load and there is then perfect load coupling between the tubes.

One important requirement for a high fidelity output transformer is that it must have negligible leakage reactance between primary windings and between the primary winding and the secondary winding. If leakage reactance is high, then transient distortion will occur due to collapsing currents when each tube is driven beyond cutoff. This current, which causes the transient condition, appears as a parasitic oscillation in the waveform at the plate current cutoff points. In addition to this high leakage reactance also causes a tremendous decrease in transformer efficiency at high frequencies resulting in poor high frequency response as well as increased distortion.

This is another great advantage of this balanced bridge circuit. Since both halves of the primary have the same signal current flowing through them no switching transients can occur when either of the tubes are driven past cut-off.

There are several other advantages obtained with this circuit. For example, due to the connections in the output transformer the impedance of the

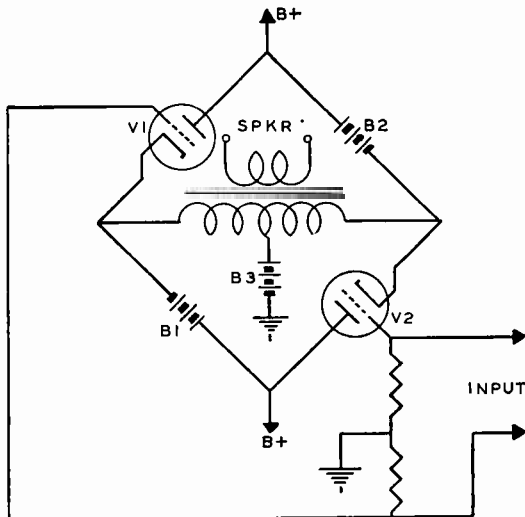

FIG. 11. Wiggins Circlotron circuit.

primary winding need be only one-fourth the impedance of the primary winding of a transformer in the conventional type output circuit with the same tubes. The lower impedance primary permits the transformer to be wound with much less capacitance than would be possible with a higher impedance. Further, the almost perfect coupling between the two tubes allows them to be operated with low quiescent current—very close to class B operation, which gives more power output.

The McIntosh Amplifier

As was discussed previously, several inherent defects are encountered with ordinary output transformers other than the obvious and expected difficulties of frequency response. In modern output transformers, it is not difficult to have a high enough primary inductance to obtain good low frequency response and a low enough leakage inductance to obtain good high frequency response. As was mentioned before, switching transients are encountered when the output tubes reach their cut-off points. These switching transients are a direct result of leakage inductance since not all of the lines of force in one-half of the primary cut the lines of force produced by the other half of the primary. These flux lines that are not coupled produce a counter emf which directly causes switching transients. Obviously, one method of eliminating such switching transients is to obtain perfect coupling and thereby eliminate the leakage inductance.

The McIntosh output transformer and associated circuit is a step in this direction. The elimination of the leakage inductance would result in unity

coupling. This is essentially what we have with this McIntosh circuit. The two halves of the primary of the transformer are bifilar-wound. That is, the two wires are laid next to each other and then wound as one wire. The coupling between the primary windings is exceptionally tight since the windings are wound together and the leakage inductance is then insignificant.

As can be seen in the basic McIntosh circuit shown in Fig. 12, the transformer is so wound that the identical winding is in the cathode circuit and the other in the plate circuit. Each winding is center-tapped.

With the circuit set up in this manner, each tube operates as a cathode follower type phase inverter with the power output being developed equally in the plate and cathode windings. Should the input signal make the grid of the top tube more positive, current flows upward from ground to the cathode of this tube and then from its plate through the lower half of the winding to B+. The bottom tube in the circuit operates in a similar manner using the lower half of the cathode winding and the upper half of the plate winding. Since the plate and cathode windings are identical and bifilar-wound, with a coupling factor approaching unity, leakage inductance is effectively eliminated and each tube appears to operate through the full primary.

The load in the secondary windings sees the two primaries as a single winding so the effective turns ratio can be halved and the plate-to-plate impedance reduced to one-quarter the optimum value for the same tubes operated in a push-pull circuit. With the impedance reduced to one-fourth, the effect of distributed capacitance of the windings is reduced by the same factor and the high frequency response of the transformer is increased appreciably.

As you can easily see, the designer of this circuit looked at it in a similar manner as the designer of the Circlotron amplifier. Both circuits accomplish a reduction of leakage inductance and consequent lowering or eliminating switching transients.

Output-Transformer-Less Amplifiers

As was pointed out several times, the output transformer in a high fidelity amplifier can cause considerable trouble. In fact, the previously rather poor quality of the output transformers was perhaps the most important limiting factor of high quality reproduction. As was seen in the discussions of the McIntosh and Circlotron amplifiers, many attempts have been made to improve output transformers in an attempt to obtain high quality reproduction. One method of improving high quality power amplifiers with respect to the output transformer is a natural one—eliminating the output transformer.

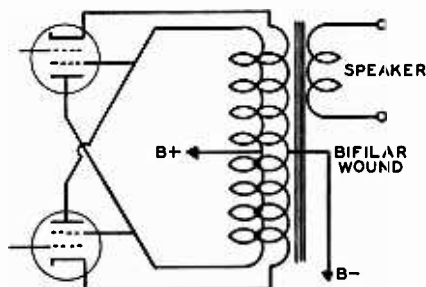

FIG. 12. McIntosh circuit power amplifier.

However, the output transformer in an audio amplifier is necessary to step down the high impedance of the output circuit to the low impedance of the loudspeaker. High fidelity loudspeakers normally have impedances from four to sixteen ohms. However, the plate-to-plate impedance of a high fidelity power amplifier will vary from about 3000 ohms to 10,000 ohms, depending upon the output tubes.

Incidentally, this is the plate-to-plate impedance of the output tubes and the necessary primary impedance of the output transformer. The actual source impedance which the loudspeaker "sees" is lower than this.

In order to eliminate the output transformer it is obviously necessary to change the usual circuit. This has been successfully accomplished by many engineers and hobbyists and descriptions of such circuits appear from time to time in the leading electronic magazines. There is, however, to date, only one commercial amplifier which does not use an output transformer. This is the Stephens "Citadel."

The usual method of eliminating the output transformer is to use a cathode-follower type output circuit. As you know, the output impedance of an amplifier is high. However, by using the cathode circuit of an amplifier for the output (a cathode-follower) the impedance can be made quite low. If the output impedance of the amplifier can be made low and if a loudspeaker can be obtained with a slightly higher than normal impedance then proper matching would result. Many manufacturers will make higher impedance loudspeakers on special order (for additional cost). For example, some very fine Stephens loudspeakers are available with an impedance of 500 ohms for only a slight additional increase in cost.

The omission of any particular high fidelity power amplifier circuit from this discussion should not be taken as a criticism of that circuit. There are just too many to be described in this News article.

SERVICING POWER AMPLIFIERS

The first step in servicing a high fidelity power amplifier is to determine if the amplifier is the cause of the trouble. Power amplifier very obviously are not used by themselves.

The best way to check a power amplifier for a defect is to substitute another one or to substitute for the other components in the system (such as the loudspeaker, preamplifier, record changer, tuner, etc.). If, after doing this, the amplifier is definitely the cause of the trouble, then normal Radio-TV trouble-shooting techniques can be employed with some modification.

Incidentally, whenever I service a power amplifier, my first step, before turning it on, is to make certain that the output transformer is not shorted in any way to B— by components in the output tube plate circuits such as feedback components from the plates of the output tubes. Such a short circuit could, when power is applied, burn out the output transformer, and keep in mind that high quality output transformers cost up to \$35. The few minutes needed for such checks have, more than once, prevented the damage of an output transformer.

It is essential to have a load connected to the output transformer secondary whenever power is applied to the amplifier or the output transformer will be damaged. Either a loudspeaker or resistor load can be used depending on the amplifier trouble and what is desired.

The Dead Amplifier

Trouble-shooting a completely dead amplifier, as with similar trouble-shooting in Television and Radio receivers, is generally begun with a test of the tubes and a check of the power supply. Tubes should be checked in a tube tester or by substitution. Then, check the power supply by measuring the B+ voltage. These two steps may lead you directly to the trouble. Of course, if all the tubes are good and the power supply is operating properly then the trouble is somewhere else in the amplifier. To locate this trouble, various methods can be used according to the preferences of the serviceman. Sometimes the characteristics of the amplifier are such that one type of servicing is preferable to another—only experience can show this.

One good method of servicing a dead amplifier is to inject an audio signal. There are several ways of doing this. If you wish you can feed the signal into the first tube in the amplifier and then with a pair of headphones follow the signal through the amplifier from stage to stage. In place of the headphones another amplifier can be used or an ordinary servicing signal tracer. Another method is to feed the signal into the various stages of the amplifier, one at a time,

beginning at the loudspeaker end until the defective stage is encountered.

When servicing an amplifier by this signal-injection method keep in mind the characteristics of the phase splitter. In many amplifiers the input of the phase-splitter stage is obtained from the output of the driver stage as shown in Figs. 4, 6, and 8. Because of this a defect in the driver stage will prevent operation of the phase-splitter stage. However, with only a glance at the circuit diagram it may seem that the trouble could be in either stage.

Incidentally, if you would prefer to use the signal injection method of servicing a dead amplifier but you do not have an audio signal generator you can usually use the audio output section of a Radio-TV rf signal generator. Just be sure that the attenuator is set properly so as to have sufficient signal to be fed through the amplifier but yet not too much to overload the first stage of the amplifier.

One other method of servicing by signal injection is to use the oscilloscope as the output indicator. When doing this be sure that the audio generator is set to a medium high frequency range so that any hum in the amplifier is not confused with the output signal that is being traced.

Incidentally, when using the audio portion of the rf generator and an oscilloscope be sure to check the output waveform of the signal generator so as to prevent confusion. Often the waveform of an rf generator is not a perfect sine wave and, if this is not known, some time could be spent in trouble-shooting an amplifier for distortion when it is actually the input signal that is distorted.

Hum

Hum is a very common audio problem. However, most of the time hum troubles occur in the preamplifier and other low level stages of a high fidelity system rather than in the power amplifier. Before trouble-shooting a power amplifier for hum make certain that the hum is actually being caused by the power amplifier and is not being fed into it from the preamplifier.

The oscilloscope is a very handy tool in trouble-shooting for hum in a power amplifier. By going from grid to plate throughout the stages the entrance point of the hum can usually be very easily and quickly located.

As with Radio and TV receivers, hum is generally caused by defective filter condensers and cathode-to-heater leakage in a tube. The output filter condenser can usually be checked by merely bridging a good one across the suspected condenser or by actual substitution. Measuring the

ac ripple voltage output of the power supply can sometimes be helpful while at other times it can lead to confusion. Extreme cathode-to-heater leakage in a tube can very often feed this hum voltage into the B+ supply where it could be measured and be suspected as a defect in the power supply.

Hum in a tube can sometimes be detected as leakage in a tube tester test. However, most of the time it is necessary to substitute new tubes that are known to be good. If you do not have any tubes that are known to be good (by being tested in other amplifiers) it is best to try two or three or even more tubes when trouble-shooting for hum. Many tubes will perform properly in Radio and TV receivers and yet will have too much hum for high gain high fidelity circuits.

Hum can also be caused by a defect in the feedback circuits of an amplifier. Normally feedback in an amplifier is used to reduce the low distortion characteristics of an amplifier to an even lower value. Sometimes, however, engineers have used feedback in a poorly designed amplifier to reduce high hum and distortion levels. A defect in such an amplifier feedback network would then result in a higher hum level than would be expected from such a defect.

In the usual push-pull output circuit the B+ voltage for the plates of the output tube is fed through the primary of the output transformer through a center tap. If the tubes are properly matched and balanced and the output transformer is of high quality so as to have balanced primary windings any hum voltage in the B+ supply fed to the primary of the transformer would be cancelled in the primary windings. Because of this, B+ voltage for the output tube plates is often obtained at the input filter condenser where there is normally a high ripple voltage. This is not an indication of poor engineering but is perfectly acceptable providing the above conditions are met. However, if a defect should occur which would unbalance the output transformer or the tubes, hum could result. Don't overlook this possibility when trouble-shooting for hum. Common defects are: one of the output tubes being weak or dead, shorted turns in one of the primary windings, etc.

Incidentally, while we are discussing hum, keep in mind that all amplifiers will produce some hum. The hum level is normally too low to be noticed. However, sometimes a customer will increase the volume control to its maximum, turn the bass control to its maximum boost position, and then noticing the hum will complain about it. All amplifiers will produce hum under these conditions and the amount of hum will depend upon the inherent design of the amplifier and the low frequency response of the speaker system. To check for normal hum level feed program material through the system either with a

record changer or a tuner and adjust the volume control to a little above the normal playing level. The treble control should then be adjusted to its "flat" position and the bass control should be slightly advanced to a position that might, under some circumstances, be used. This is almost never its maximum position. After the controls have been set remove the source (record or tuner), disconnecting it from the amplifier, and listen critically for hum from the loudspeaker. In very high quality systems hum should not be heard while listening right at the speaker while in medium and low price systems some hum is normal within two or three feet of the speaker. In any case, at normal control positions, the hum should not be loud enough to interfere with the program material nor to be annoying during quiet passages as between bands on an LP record.

Noise

As with hum, noise is generally caused by a defect in the low level amplifier stages rather than in the power amplifier stages. However, an extremely noisy tube in the high level stages can cause this trouble. As indicated previously, a new tube, known to be good, should be substituted.

Noise can often be caused by resistors and substituting new resistors will usually clear up the trouble. It is usually best, in such cases, to replace a noisy resistor with one of higher wattage value (which tends to reduce the noise). Half watt resistors should be replaced with 1-watt resistors, 1-watt resistors with 2-watt resistors, etc. It is generally not feasible to go over 2 watts unless, of course, the original resistor was of higher wattage. That is, replace a 5-watt resistor with a 5-watt resistor but replace a ½-watt resistor with a 1-watt unit.

When trouble-shooting an amplifier for noise it is unsatisfactory to use a radio signal tracer because of its normally high noise level as compared with Hi-Fi equipment. It is usually essential to use a pair of high fidelity headphones or another high fidelity amplifier for such signal tracing.

Distortion

This is the most difficult form of trouble to track down. One of the best methods of tracking down distortion is to feed normal program material such as from a tuner or a record into the input of the amplifier and then trace through the amplifier from stage to stage with a pair of high fidelity headphones or another Hi-Fi amplifier being used as a signal tracer.

There are many types of distortion which can occur in power amplifiers—frequency distortion, harmonic distortion, intermodulation distortion, transient distortion, phase distortion, etc., to name a few. Fortunately, most of these types

are peculiar to the design of the amplifier and not to its servicing. The distortions most often encountered by the serviceman are non-linear distortions such as harmonic and intermodulation. Any defect which can cause one of the other types of distortion such as transient or frequency, generally also cause non-linear distortion which, by the way, is the most annoying type.

Non-linearity in any stage will cause both harmonic and intermodulation distortion. Harmonic distortion is the improper amplification of harmonics or the addition of harmonics which are not present in the original signal. Intermodulation distortion is the modulating of the high frequencies by the low frequencies. This causes sum and difference signals to arise.

The harmonics introduced or incorrectly amplified due to harmonic distortion are musically related to the signal but the sum and difference signals produced by intermodulation distortion are not musically related to the signal. Because of this, intermodulation distortion is more annoying than harmonic distortion.

Non-linearity in a stage is generally caused by a change of value of the plate or cathode resistors. Previously described signal tracing methods can be employed to locate the stage causing the distortion and then the defective part can be found with an ohmmeter.

Incidentally, when trouble-shooting for distortion don't overlook the possibility of secondary troubles. For example, a leaky coupling condenser will usually apply a positive voltage to the grid of a tube, upsetting the bias and causing distortion. However, the excessive plate current of that tube resulting from the positive voltage on the grid may increase or decrease the ohmic value of the plate resistor. Replacing the coupling condenser and tube would then still not clear up all of the distortion because of the damaged plate resistor. Remember that the resistor need not be visibly burnt to have changed value.

Harmonic and intermodulation distortion analyzers which are available both factory-built and in kit form can be very useful tools to the high fidelity service man. However, when using these instruments keep in mind that you should not expect all high fidelity power amplifiers to have distortion levels as low as the manufacturer's specifications state. The distortion level given in the specifications should be for a typical power amplifier of that particular model. However, it may not be! First of all, the tolerances of the distortion level are seldom given in the specifications and they can be as much as plus or minus 50%—this is not unusual. Furthermore, the method of measuring the distortion is not given either. Some manufacturers list the distortion level for the over-all amplifier including the preamplifier and control unit. Other manufac-

turers measure only the distortion of the power amplifier. Other factors can affect such specifications. For example, the distortion with a resistive load connected to the output of the amplifier may be lower than the distortion measured with a loudspeaker load.

Since distortion is greatly affected by the feedback methods in the amplifier, a defect in a feedback loop is a common cause of amplifier distortion.

Some amplifiers use only one loop of inverse voltage feedback which is generally taken from the secondary of the output transformer and fed to the driver tube cathode. However, there are many amplifiers with more than one feedback loop or with different types of feedback. For example, the Bogen DB110 uses a special type of feedback called controlled positive feedback while the UTC amplifier kit employs many feedback loops. In addition to these various types of fixed positive and negative feedback, the current trend in amplifiers is to include variable current feedback which enables the user to adjust the damping factor of the amplifier. Damping factor is a ratio of the load impedance to the output impedance of the amplifier. (The output impedance of the amplifier is the impedance that the loudspeaker "sees"—not the plate-to-plate impedance of the output tubes.) This adjustable damping provision may be known by some other name. Bogen calls it "variable damping factor" while Fisher labels it "Z-Matic."

In conclusion, the servicing of high fidelity power amplifiers does not present any particularly difficult problems. The servicing techniques proven successful in Radio-TV work are usually applicable with some modifications (as explained) providing the serviceman keeps in mind the normally high quality of reproduction to be expected from these amplifiers.

————— n r i —————

The applicant presented his credentials with confidence but the manager read them very dubiously.

"It is certainly a fine thing for you to have these recommendations from your minister and your Sunday School teacher, but I'd like to have at least one recommendation from someone who knows you on week days."

————— n r i —————

"If you want knowledge, you must toil for it; if food, you must toil for it; and if pleasure, you must toil for it. Toil is the law. Pleasure comes through toil, and not by self-indulgence and indolence. When one gets to love work, his life is a happy one."

—John Ruskin

Our Cover Photo

The energetic-looking young man who appears on the cover of this issue is NRI Graduate William F. Kline, who owns and operates the N. L. Fessenden Appliance Company, 5905 Madison Road, Madisonville, Cincinnati 27, Ohio. The story of Graduate Kline's success is given in the feature appearing below.

The Success Story of NRI Graduate William F. Kline of Cincinnati, Ohio

NRI Graduates use their training in many ways, such as in industry, TV servicing, communications, etc. However, if there is one dream common to many NRI Graduates, it is the dream of "owning one's own business." Here is the story of how Graduate William F. Kline has achieved that dream.

In 1938, William Kline graduated from high school. Like many new high school graduates, he immediately took a job. He started as a laborer at a machine tool company in Cincinnati, Ohio. Kline worked hard in his career as a machine tool operator, advancing to the position of machinist and finish-grinder at the end of his first four years. Soon, he was making as much money as men who had spent all their working lives as machinists in this plant. But, he was not satisfied. He began casting around for something in which advancement was not restricted at the top.

In the summer of 1939, he enrolled with the National Radio Institute. He completed his training on June 10, 1941. After his graduation, he began to get into Radio and Television service gradually, through taking on part-time jobs, working at night. Between his regular work and his part-time earnings, he saved \$4000 in cash. This was enough to purchase the business which he now operates.

In 1952 he purchased the N. L. Fessenden Appliance Company, which was at that time a successful appliance business, specializing in "white goods." The business had been operating for thirty years. However, the business was doing very little in Television and Radio and employed only one



NRI Graduate William F. Kline

other person in addition to the previous owner.

Today, this successful appliance business has been expanded to the point where Television accounts for three-fifths of the gross and white goods for only two-fifths of the gross income. In 1955, Graduate Kline's business grossed \$115,000. Aside from Mr. Kline, four persons are now employed, consisting of an appliance sales person, an appliance repairman, and two Radio-TV servicemen.

Graduate Kline enjoys a respected position in his community. He is active in civic affairs and has been invited to join one of the local country clubs as well as other organizations. He enjoys a position in life which he has built for himself. His is a dream come true.

In regard to opportunities for men in Radio-TV-Electronics, Graduate Kline is quoted as follows:

"There are jobs everywhere waiting for NRI-trained men. NRI got me started on the road. It gave me a purpose and opened my eyes to what I could work toward. As far as I can see, the opportunity in Television is unlimited."



N.R.I. ALUMNI NEWS

Louis E. Grossman	President
F. Earl Oliver	Vice Pres.
Howard B. Smith	Vice Pres.
William Fox	Vice Pres.
Herbert Garvin	Vice Pres.
Louis L. Menne	Executive Secretary

Chapter Chatter

Milwaukee Chapter Members were visited by L. L. Menne and T. E. Rose. On that occasion Mr. Donald Ruplinger conducted our members through the School of Engineering. This tour was high-lighted by direct questions and answers between our group and our guide.

At another meeting our member Mr. James Lasky, a successful serviceman, lectured on Horizontal and Vertical Synchronization plus Vertical Drift Problems in TV.

Milwaukee Chapter News, our own little publication, has secured some full-page advertising which will help defray cost of publication. Our thanks to Chairman Ernie V. Bettencourt, the Editor, and our member Mr. Opperman, for the good work they have done soliciting advertising accounts. Our members are very much interested in our local publication which is humming along.

Meetings are held on the third Monday of each month at Petrich's Radio and Television Shop, 5901 W. Vliet Street, Milwaukee.

We cordially invite students and graduates in this area to attend meetings. Please contact Chairman Ernest V. Bettencourt, 3407A North First Street, Milwaukee 12, Wisconsin or Secretary Robert Krauss, 2467 North 29th Street, Milwaukee.

New York Chapter members are always assured of a very fruitful meeting by reason of the large staff of capable lecturers in their group.

Chairman Thomas Hull spoke on TV Sound IF's. Phil Spampinato spoke on Improving AC-DC Audio.

Presumably New York Chapter offi-

Page. Twenty-four

cers will again suspend meetings during July and August as in former years but no official notice has been received at headquarters. Except for this suspension during the two warm summer months meetings are held regularly on the first and third Thursday of each month at St. Marks Community Center, 12 St. Marks Place, (between 2nd and 3rd Avenues) New York. The Chairman is Thomas Hull, 119-18 223rd Street, Cambria Heights, New York. The Secretary is E. E. Paul, 6 Gateway, Bethpage, L. I., N. Y.

Philadelphia-Camden Chapter is pleased to announce the following new members since last report. They are John H. Meyer, William Barron, Edward Debicki, all of Philadelphia and Benjamin Morris of Gloucester, New Jersey.

As this issue goes to press Secretary Jules Cohen announces that elaborate plans have been completed for the dinner party scheduled for May 28. Members from a number of Chapters have
(Page 26, please)



A good representative group of Milwaukee Chapter members. A fine lot of men you NRI students and graduates in Milwaukee should meet, if you are not now a member.

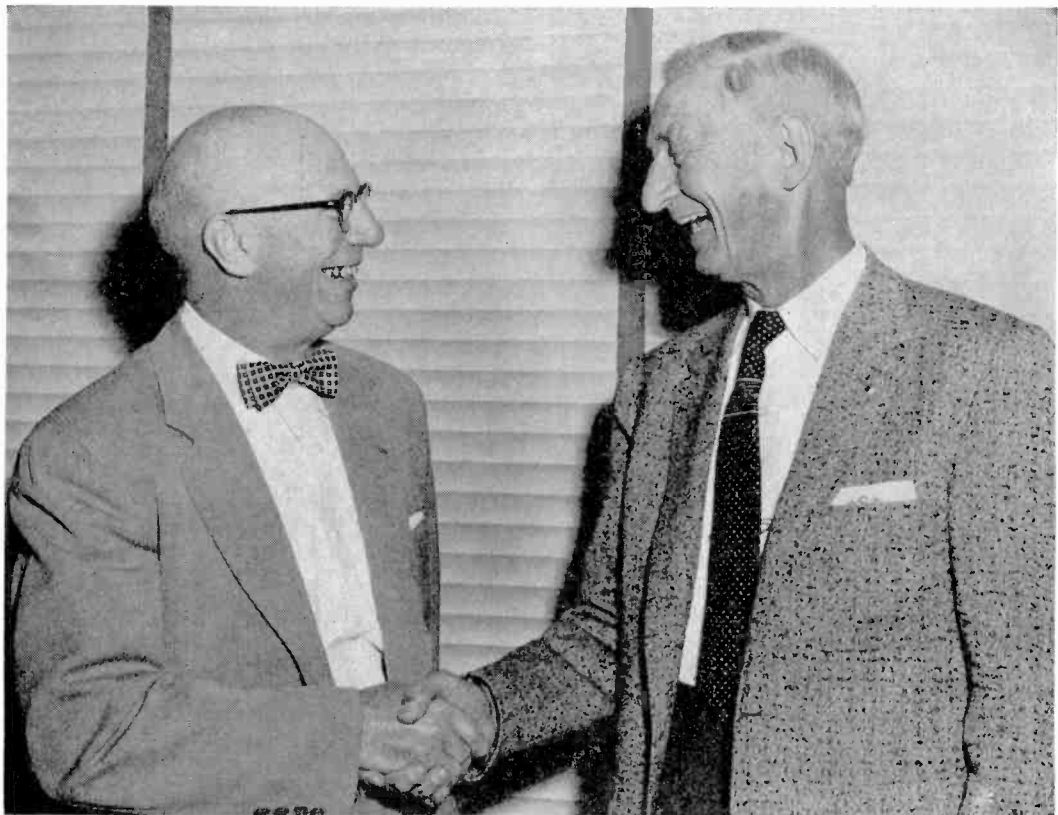

J. E. Smith, President of NRI, extends hearty congratulations to Lou Menne on his completion of nearly twenty years as Executive Secretary of the NRI Alumni Association.

With mixed emotions—I tell you that on June 30, Louis L. Menne will retire from the National Radio Institute.

You wouldn't know it to look at him, or to watch him at work or at play. But Lou has reached the age at which—in accordance with an NRI policy we consider proper and wise—each member of the National Radio Institute Staff is automatically retired.

He reaches his sixty-fifth birthday (within a few weeks of the time when he would have been with NRI for twenty years) serving in these multiple capacities: Director of Graduate Service, Director of Supply Division, Editor of NATIONAL RADIO-TV NEWS, and Executive Secretary of the NRI Alumni Association.

In many, many ways I regret to see Lou go. He is my close personal friend. He is a capable NRI executive upon whose judgment, advice and ability I have depended for many years.

NRI will miss him. We will miss his wise and experienced counsel—his able management of important departments of this organization—his loyal, cheerful, friendly presence.

And you will miss him, because for many years, Lou has been an aggressive, conscientious representative of the interests of all NRI men.

But Lou Menne has richly earned the right to take it easier in the years to come.

And I am happy that he retires while in good health—and with the enthusiasm and spirit to enjoy himself.

L. L. Menne will be succeeded by a man he has helped train to take over his many and exacting duties. This man is Theodore E. Rose—concerning whom I will tell you more in the next issue of NR-TV News.

J. E. SMITH

Page Twenty-five

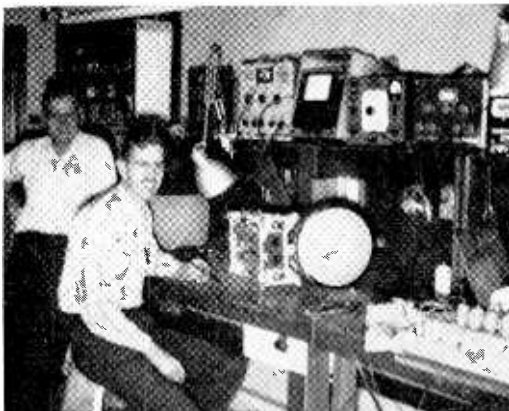

Harvey Morris, TV specialist at Phila-Camden chapter, at work in his shop. He is assisted by Fred Mascavis, on left.

New Orleans Chapter members continue to meet in the recreation room of President Louis E. Grossman, 2229 Napoleon Avenue. The Chapter is well supplied with equipment and instruments including the NRI TV Oscilloscope.

Members have found it delightfully interesting to repair a number of television sets for the Crippled Children's Hospital in New Orleans. Mr. Grossman personally paid for the necessary parts. A very heart warming acknowledgement was received from Elizabeth Miller Robin, President of the Hospital, who spoke of the great joy the children receive through the use of the television sets.

Meetings for the most part are devoted to actual servicing of Radio and Television receivers. This is an opportunity for students and graduates in this area to become acquainted with men who are interested in the same type of projects as are all students and graduates. A cordial welcome is assured to all. Contact Chairman Alfred Francis, 1928 Louisa Street, New Orleans 17, La. or Secretary Anthony Buckley, 305 Serpas Drive, Arabi, La.

St. Paul-Minneapolis Chapter held a special meeting on May 10 to celebrate the 2nd anniversary since the chartering of the Chapter. First the members attended a banquet at Erslinger's Cafe. An interesting program was arranged. A vote of thanks to the entertainment committee. Following the dinner, we piled in automobiles and went to our regular meeting place at the Midway YMCA in St. Paul where the program was under the direction of L. L. Menne and T. E. Rose, who were our guests from Washington. The newly elected officers of our Chapter were installed by Mr. Menne.

Elected officers are, Chairman Paul Donatell, Vice Chairman Nick Barrett, Secretary Charles Goodell, Treasurer George Dixon, Sgt. at-Arms Clarence Bakken.

At one of our meetings Mr. William MacIntosh demonstrated the use of test equipment. Mr. MacIntosh is connected with the Stark Radio Supply Service, who are well known in this area and who have given splendid cooperation to our chapter members.

Meetings are held on the second Thursday of each month at the Saint Paul Midway YMCA beginning at 8:00 P.M.

Baltimore Chapter members rolled out the carpet with a social party attended not only by members but by a number of members from Philadelphia-Camden Chapter including Chairman John Pirrung, Treasurer Charles J. Fehn and Secretary Jules Cohen. The names of other Philadelphia-Camden Chapter members who attended this affair, as guests, were not recorded

indicated they will make the trip to Philadelphia to attend this party. Mr. J. E. Smith, J. M. Smith, T. E. Rose, J. B. Straughn and L. L. Menne from Headquarters will also be present. This party has been arranged as a tribute to L. L. Menne who is retiring as Executive Secretary of the NRI Alumni Association.

The program committee has arranged for a speaker from the Philco Organization and another from the Zenith Company. Interspersed between these talks we have some very fine bread and butter lectures by Harvey Morris, our TV expert. One of the talks Harvey made recently was on Audio Circuits and Trouble Shooting Methods in the intercarrier circuit. The members really enjoyed this talk.

A group of our members made a tour through the Bell Telephone Lab and learned a great deal about Closed Circuit TV and Microwaves.

Mr. Warren Bond and Mr. Herb King of the Philco Educational Service Division give a very interesting presentation of the Philco 330-390-440 Chassis, Service bulletins and schematics were given to members to make it easy to follow the lecture.

Chairman John Pirrung is getting fine cooperation from our officers. Our meetings are very productive and well attended. We meet on the second and fourth Monday of each month at the Knights of Columbus Hall, Tulip and Tyson Streets in Philadelphia. During the past four months ten members were admitted to our Chapter. We wish it known that all students are welcome at our meetings. We shall be glad to have you communicate with Secretary Jules Cohen, 7124 Souder Street in Philadelphia.



Baltimore Chairman Joseph B. Dolivka checks with Secretary Joseph M. Nardi, (seated) before calling a meeting to order. Wilbur Kidd and Treasurer John E. Harp take part in the proceedings.



Elmer E. Shue and H. J. Rathbun in serious discussion. Two sturdy pillars of Baltimore chapter.

but their presence was greatly appreciated.

All normal business activities were suspended in order to permit more time for the evening's festivities. Guests from Washington were T. E. Rose, J. B. Straughn and L. L. Menne. The theme of the meeting was to accord our retiring Executive Secretary, Mr. L. L. Menne, official recognition and commendation for his meritorious services as Executive Secretary of the NRI Alumni Association. In keeping with the occasion, Mr. Menne delivered an impressive talk, summarizing the high-lights of his career and particularly his twenty year reign as Executive Secretary of the Alumni Association. He assured our listeners that the solid foundation upon which the NRI Alumni Association is built, the loyalty

of its members and the deep interest and enthusiasm of staff members at NRI can mean only continued growth and greater accomplishments for our organization.

Chairman Joseph B. Dolivka conducted the meeting in his usual good style and entertained for some length with interesting anecdotes.

Baltimore Chapter meetings are held regularly on the second Tuesday of each month at 100 North Paca Street, 8:00 PM. Secretary is Joseph M. Nardi, 4157 Eierman Ave., Baltimore.

Hagerstown Chapter members continue to meet at the YMCA on the second Thursday of each month. Members take a leading part in the programs which have been very interesting.

Students and graduates in the Cumberland Valley area are invited to attend meetings. A cordial welcome will be extended by the officers and members. The Chairman is Edwin M. Kemp, 618 Sunset Avenue. The Secretary is John Pearl, 13 Fairground Avenue in Hagerstown.

Secretary John Pearl, by the way, gave a very comprehensive demonstration of aligning a TV using a sweep generator and a scope. He also demonstrated the new Finco Geomatic Antennas. Members declared this meeting one of the finest this year. Attendance was exceptionally good.

At another meeting Mr. Harold Kuhns gave some interesting comments regarding the NRI Radio-TV Communications course which he is taking.

Detroit Chapter members again express appreciation to Mr. George Kangas of the Hickok Instrument Company who demonstrated the use of equipment. Our Summer stag party is scheduled for June 22. It will be held at the Chry-Moto Club in Windsor, Ontario, Canada. Our former chairman Clarence McMaster is making all arrangements. This is usually a big event and



Mr. George Kangos of Hickok demonstrates the use of a Sweep Alignment Generator, Marker Generator, and Marker Adder at Detroit meeting.



A picture of members of our fast growing chapter in Pittsburgh.



Bert Bregenzler, widely known TV authority and Honorary Member of Pittsburgh Chapter installs the elected officers of that chapter. From left to right, Sylvester Steyer, Lawrence Steyer, David Benes, Earl Uhl, Peter Kenny, Francis Skolnik and William Lundy, the chairman.

all members are urged to attend.

Meetings are held on the second and fourth Friday of each month at 431 East Congress Street in Detroit. Meetings begin at 8:00 PM. Discussions of deep interest to Radio and TV technicians who operate in the city of Detroit are held at these meetings.

Contact Chairman Edward V. Green, 9458 Knodell Avenue or Secretary James Kelley, 1140 Livernois in Detroit. It is customary for Detroit Chapter to suspend meetings during July and August. It is presumed this practice will again prevail this year although headquarters has received no official notice to this effect.

Pittsburgh Chapter members were addressed by Mr. Clem Kraski, a Radio-TV Wholesaler who spoke on Signal Injection in Sweep Circuits. There were further talks on the use of the Oscilloscope by Mr. Clement McKelvey.

At another meeting Mr. McKelvey spoke on aligning a TV receiver. He showed movies pertaining to alignment. This was very interesting indeed.

A delegation of Pittsburgh members will attend the meeting in Philadelphia on May 28.

Meetings are held on the first Thursday of each month at 8:00 PM. at 134 Market Street. We



Vice Chairman Howard B. Smith of Springfield Chapter, at the blackboard.



A group of Springfield Chapter members.

The members expressed deep appreciation to NRI for cooperation in establishing the Chapter. Interesting talks were made by Howard B. Smith and Lyman L. Brown as well as Chairman Nystrom.

Mr. Howard B. Smith, who is a national Vice-President, spent two days in Washington as a visitor at NRI. His interest in the welfare of our Alumni Members is unbounded.

The Secretary of Springfield Chapter is Marcellus Reed, 41 Westland Street, Hartford, Conn.



Chairman Ray Nystrom, assisted by Henry Merheb, cut the cake at the second anniversary meeting of Springfield Chapter.

Chicago Chapter is going good with Chairman Walter H. Nicely doing a nice job on programs. We need to enlarge our group and welcome new members. Parking facilities are now much improved. Meetings are held on the second and fourth Wednesday of each month, at 666 Lake Shore Dr. Please use West entrance.



Walter H. Nicely and Harry Hassler of Chicago Chapter, both with Delta Airlines.

have very pleasant and comfortable meeting quarters. If you live in this area and are not a member of the Pittsburgh Chapter we assure you a hearty welcome. The Chairman is William J. Lundy, 263 Morrisey Street. The Secretary is Peter Kenny, Jr., 8111 Lindisfarne Drive, Pittsburgh.

Springfield-Mass. Chapter is growing steadily. At one meeting Vice Chairman Howard B. Smith spoke on Fundamentals of Radio and Television.

The chapter recently celebrated its second anniversary. Chairman Raymond Nystrom and his committee presented the chapter with a huge cake. Coffee and other refreshments were served. Coincidentally, our second anniversary celebration was held on the birthday of Chairman Nystrom.



A group of Chicago chapter members when Ted Rose and Lou Menne were visitors. Chairman Walter Nicely is at left. The gentleman in the center with hat on his knee is William B. Rusch who has a very successful Radio-TV business in Dixon, Ill.

A Closing Word from Ye Editor

As ye editor lays down his pen, after twenty years of scribbling, scratching and scrambling to fill these columns with items of interest, he wishes to thank all of the officers of our local chapters, past and present, and all of our national officers, who have contributed so much to the growth of our organization. A tip of the hat to every single member of our Alumni Association, now numbering more than 15,500, for deep loyalty and splendid cooperation.

It is a great satisfaction to have had the opportunity to grow with the NRI organization and to have made so many friends among students and graduates.

To George Rohrich, Robert A. Boardway, Tom Carswell, Leo M. Conner, John G. Dodgson, James J. Kelly, Don Kline, Hugh Littlejohn, Don Looney, Vernon Messick, Don Quade, B. van Sutphin, James P. Tate, Jr., and especially Technical Editor J. B. Straughn and Associate Editor H. L. Emerson, who often did the work for which the Editor took the bows—a big

thank you—an orchid to my Secretary, Claire Porter, for unbounded aid in remembering dates, events and for great help in keeping the ship on a straight course during rough seas—not to overlook the very fine little ladies in the NRI Central Typing Division who have been so patient and tolerant with sometimes badly prepared copy or hurried dictation—a well deserved mention for fine work by the boys who set the type at the printing plant, and a grateful salute to Educational Director, William F. Dunn, who is cooperation personified. A great team who make the job of getting out this publication a proud work and a pleasure.

In print and in person ye editor has tried to meet the high standards set by J. E. Smith, the Founder of NRI.

Good luck and remember—come what may, keep your chin up, and keep plugging. The world is crying for doers. Set your goal high and keep after it.

L. L. Menne

"On The Job" Training

An excellent opportunity exists for a "bright" high school graduate. Should be good in mathematics and have good knowledge of basic electronics. A six month training period will be given "on the job."

The opportunity is for a field engineer in the Washington, D. C. Office of Logistics Research, Inc. Starting salary is approximately \$350 per month. Some traveling will be involved. If interested, a letter of application should be sent to Mr. Victor White, 12316 DaleWood Drive, Silver Spring, Maryland.

Electronic Parts Stock Clerk

The Electronic Engineering firm of Jansky and Bailey, Inc., 1735 DeSales St., Washington, D. C., has an opening for a young man to start as a stock clerk in an electronic laboratory. Beginning salary \$60-\$70 per week (40 hours). If interested, direct inquiry to Mr. H. D. Kube, Jansky and Bailey, Inc., address above.

Service Technicians

Industrial Nucleonics Corporation, 1205 Chesapeake Ave., Columbus 12 Ohio, has openings for service technicians. Write to Carroll D. Atwood, Asst. Personnel Manager for application information.

Apprentice Service Engineer

Tracerlab, manufacturers of nuclear counting equipment, has opening for apprentice service engineer in Washington, D. C. field office. Training period. Should have car. Write to R. D. Armiger, Tracerlab, 226 Mass. Ave., N.E., Washington, D. C.

INDEX

Article	Page
Editorial	2
Auto Radio Parts Replacement	3
Simpson Model 260 Available from NRI ...	10
Employment Opportunities	12, 13, 30
High-Fidelity Audio Power Amplifiers	14
Our Cover Photo	23
NRI Alumni Association News	24
Here and There Among Alumni Members ..	31



Here And There Among Alumni Members

Graduate Clark F. Conaway, of Knightstown, Indiana, has signed a franchise for the complete line of Westinghouse products. He is adding major appliances to his already successful Radio and TV Sales and Service business.

— n r i —

Mr. William B. Rusch of Dixon, Ill., made the trip to Chicago to be present when Ted Rose and Lou Menne dropped in for a visit. Mr. Rusch made a short talk that would inspire any young man. He is responsible for enrolling about a dozen students with NRI and he takes a personal interest to see that they get the most out of their studies.

— n r i —

Graduate Willard Doan, of Arlington, Texas, is FM and TV Transmitter Engineer for WBAP-AM-FM-TV.

— n r i —

National Vice President F. Earl Oliver was ill but is now fully recovered. Glad to have him back at meetings in Detroit.

— n r i —

Gerald A. Miller, of Newington, Conn., is now working for General Motors, in the Meriden plant of New Departure, maintaining electronic equipment. Miller is an NRI graduate of 1926, and a loyal NRIAA member.

— n r i —

Alumni President Louis E. Grossman is proud as a peacock because his daughter Joel made Phi Beta Kappa. She graduates from college May 28th. Those of us who have met Joel and her equally brilliant brother, Rene, are not surprised. These youngsters have a gift of genius.

— n r i —

Armand Gaumont, of Burbank, Calif., is now working as a trainee Electronics Research Technician with Lockheed.

— n r i —

Graduate Walter M. Schmidt of Nevada, Iowa, is enrolled at Iowa State College where he is working for his BS degree in Electrical Engineering. Says his NRI course aroused in him a deep interest to advance further, hence his enrollment at college.

— n r i —

Graduate Thomas J. French, of Santa Monica, Calif., has just retired after 21 years of Naval Service. He expects to begin working soon as an electronic laboratory technician with Douglas Aircraft.

Wallace L. Cooper of Kansas City, Missouri specializes in auto radio service, on a part time basis. But he has all plans made to open a full time shop very soon.

— n r i —

Graduate Noah Magee, of Pendleton, Indiana, recently received a Suggestion Award of \$1300 from his employer. Magee works in the Delco-Remy division of General Motors.

— n r i —

Perry Fuller, of Deel, Va., has his own Radio-TV Service business. Averaging about \$100 per week.

— n r i —

Edward Mehl of Brooklyn operates a Radio-TV shop and is now pursuing NRI's course in Servicing Electrical appliances.

— n r i —

Graduate Richard L. Pottmeyer, of Fleming, Ohio, is employed as an Industrial Instrument Technician with B. F. Goodrich. Does maintenance work on industrial electronic controls. Getting along fine.

— n r i —

R. W. Tilson of Biltmore, N. C. passed the FCC examination for a first class Radio telephone operator's license. Also has an amateur operator's license. Call is W4VQA. Working for Radio Station WWNC.

— n r i —

C. Wendling, of Detroit, Michigan, writes enthusiastically about his job in industrial electronics. Says pay is excellent and opportunities unlimited.

— n r i —

Lester Griffith of Clay Center, Kansas, has been placed in charge of the service department for an RCA dealer. They service everything from Inter-coms to Electronic organs.

— n r i —

James Totin, of Vintondale, Penna., has received his second class radiotelephone license.

— n r i —

Bob Miller, of San Diego, California, received his 2nd class radiotelephone license recently and now has a new job on UHF transmitting gear at double his previous salary. Congratulations to you, Bob!

— n r i —

Thomas Bilak, Jr., of Cayuga, New York, writes that he has received steady promotions, and is now working on printed wiring board design, which he finds very interesting. Bilak is employed at the General Electric Advanced Electronics Center, Ithaca, New York.

NATIONAL RADIO-TV NEWS
16th & U Sts., N.W. Washington 9, D. C.

Forwarding Postage Guaranteed

~~Mr. Francis H. Fingado
611 17th St.
Denver 2, Colo.~~

25236-G

4A

*1453
Cecil
pm*

Second-class mail
privileges authorized
at Washington, D. C.